

Hardware Manual

commModule MBP Evaluation Kit



Disclaimer of liability

The information contained in these instructions corresponds to the technical status at the time of printing of it and is passed on with the best of our knowledge. Softing does not warrant that this document is error free. The information in these instructions is in no event a basis for warranty claims or contractual agreements concerning the described products, and may especially not be deemed as warranty concerning the quality and durability pursuant to Sec. 443 German Civil Code. We reserve the right to make any alterations or improvements to these instructions without prior notice. The actual design of products may deviate from the information contained in the instructions if technical alterations and product improvements so require.

Trademarks

FOUNDATION™ and HART® are marks of the FieldComm Group of Austin, Texas, USA.
Modbus® is a registered trademark of Schneider Electric, licensed to the Modbus Organization, Inc.



OpenSource

To comply with international software licensing terms, we offer the source files of open source software used in our products. For details see <http://opensource.softing.com/>

If you are interested in our source modifications and sources used, please contact: info@softing.com

Softing Industrial Automation GmbH

Richard-Reitzner-Allee 6
85540 Haar / Germany
<http://industrial.softing.com>

 + 49 89 4 56 56-340
 + 49 89 4 56 56-488
 info.idn@softing.com
support.automation@softing.com



Scan the QR code to find the latest documentation on the product web page under Downloads.

Table of Contents

Chapter 1	Introduction	5
1.1	About this document.....	5
1.1.1	Target group	5
1.1.2	Related documentation	5
1.1.3	Conventions used	5
1.1.4	Document history	5
1.2	Scope of delivery.....	5
Chapter 2	commModule MBP Evaluation Kit.....	6
2.1	Block diagram.....	6
2.2	Internal interfaces.....	7
2.2.1	Jumper	7
2.2.2	Programming connector	9
2.2.3	Adjusted output	10
2.3	External interfaces.....	11
2.3.1	Fieldbus	11
2.3.2	HART/Modbus	11
2.3.3	LED	11
Chapter 3	Electrical specifications.....	12
3.1	Operating conditions.....	12
3.2	Input and output.....	12
3.3	Fieldbus	12
Chapter 4	Appendix	13

This page is intentionally left blank.

1 Introduction

1.1 About this document

The commModule MBP is a surface mountable, single-sided communication module with minimum footprint designed to access the Fieldbus Foundation.

1.1.1 Target group

This document is addressed to HART device developers and software engineers. Basic knowledge of HART and FF technology and HART device descriptions is assumed to ensure that the steps and processes described in this document are implemented correctly.

1.1.2 Related documentation

For further details about the commModule MBP and the configuration workflow of the firmware see the CommScripter user guide and commModule MBP hardware guide available by [download](#).

1.1.3 Conventions used

The following conventions are used throughout Softing customer documentation:



CAUTION

CAUTION indicates a potentially hazardous situation which, if not avoided, may result in minor or moderate injury.



Note

This symbol is used to call attention to notable information that should be followed during installation, use, or servicing of this device.



Hint

This symbol is used when providing you with helpful user hints.

1.1.4 Document history

Document version	Modifications compared to previous version
1.00 - initial version	none
1.10	Simulate Enable X5 and Protocol Select X7 jumper ^[7] functions updated.
1.20	Flash memory block ^[9] descriptions updated. Reference to related documentation updated. Trademark notice and Open Source notice added.
1.20.1	Circuit diagram ^[13] added.

1.2 Scope of delivery

The Evaluation Kit consists of the commModule MBP board with minimum footprint, packed with two interface connectors into a box with LED and removable cover.

2 commModule MBP Evaluation Kit

The commModule MBP is a surface mountable, single sided communication module with minimum footprint. It is mounted on a carrier board which exhibits internal and external interfaces along with additional circuitry like EMC protection and current limitation.



CAUTION

The commModule MBP Evaluation Kit must not be used in hazardous areas.

2.1 Block diagram

The block diagram of the commModule MBP Evaluation-Kit is shown below:

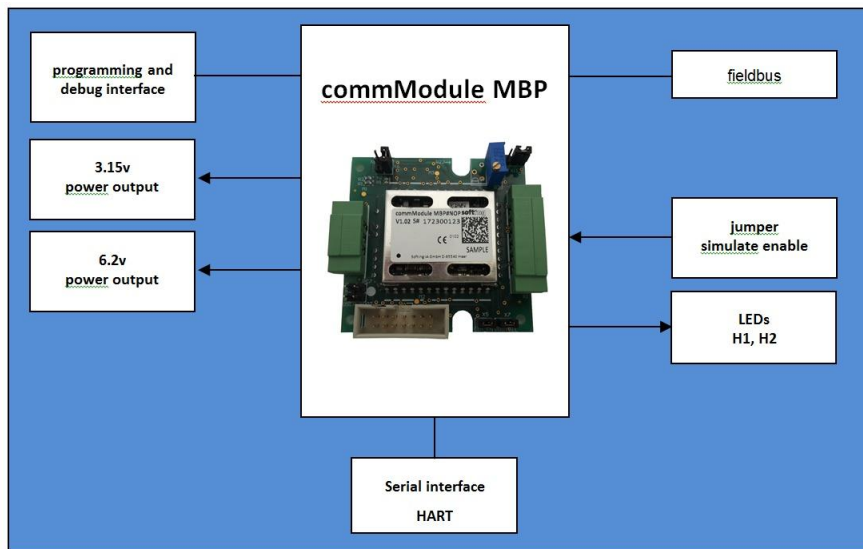

2.2 Internal interfaces

To access the internal interfaces, the enclosure must be opened. Unscrew two screws from top and carefully remove top cover.

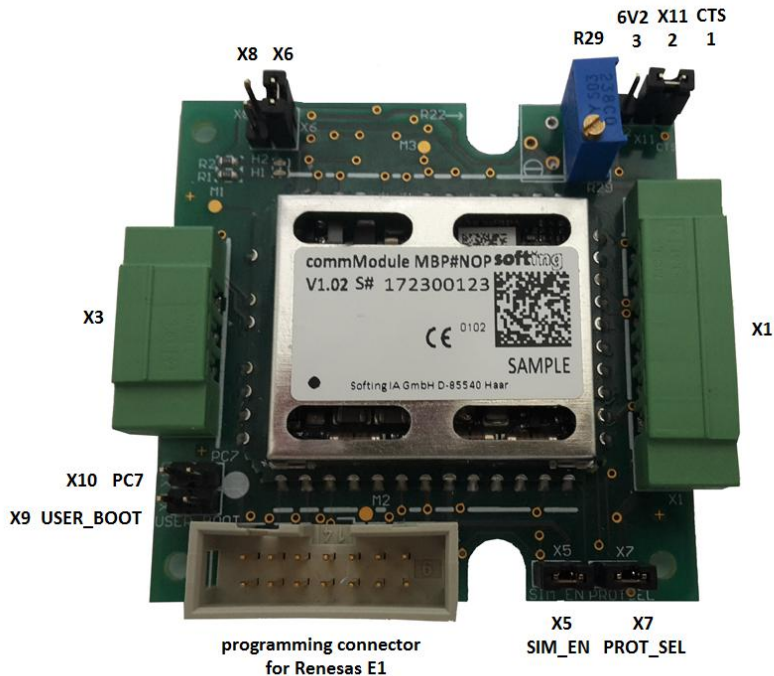

2.2.1 Jumper

USER Boot Mode X9

This jumper is not used. Please leave open.

PC7 X7

This jumper is not used. Please leave open.

Simulate Enable X5

Default: Leave open

Fieldbus interoperability testing requires switching the application to simulate mode.

Simulate mode is enabled by signaling low on pin SIM_EN_P31.

This mode must be accessible for the fieldbus testing personnel.

Protocol Select X7

When the jumper is open, the FF protocol software will be booted. When the jumper is connected, the PA stack will be booted.

Default: Leave open (-> FF software will start)

CTS/6V2 X11

Connect Pin 1 and 2 with Jumper to connect CTS signal to Pin 5 of X1

Connect Pin 2 and 3 with Jumper to connect 6V2 power rail to Pin 5 of X1.

Default: Connect pins 2 and 3

LED H1 X6 (green LED)

Install jumper to connect pin LED_GPIO_PE1 to LED H1

LED H2 X8 (red LED)

Install jumper to connect pin LED_GPIO_PE2 to LED H2



Note

If a LED jumper is installed, this will add approximately 1.3mA current consumption on the 3V15 power rail per LED.

2.2.2 Programming connector

Connect Renesas E1 emulator for flash programming and debugging on connector X2 as shown below:

Signal name	I/O	Description	14 pin Renesas fine interface
TDO	DBG	only used for internal flash programming with Renesas Flash Programmer	5
TDI	DBG	only used for internal flash programming with Renesas Flash Programmer	11
FINED	DBG	programming interface	7
PC7	DBG	programming interface	10
#RESET	DBG	programming interface	13
GND	GND	GND	2, 12, 14
3V15	VCC	supply voltage from device	8



Note

Use only programmer projects provided by Softing. Do not delete or reprogram the flash memory blocks below as you will no longer be able to boot the commModule MBP. If this happens you will need to send the commModule MBP in for repair.

User Boot Area:

Block 1158: 0xFF7F800 - 0xFF7FFFF (32kB)

Trusted memory:

Block 8: 0xFFFE8000 - 0xFFFEFFFF (32kB)

Block 9: 0xFFFE0000 - 0xFFFE7FFF (32kB)

Production data:

Block 1152: 0x0010FE80 - 0x0010FEBF (64B)

Block 1153: 0x0010FEC0 - 0x0010FEFF (64B)

Block 1154: 0x0010FF00 - 0x0010FF3F (64B)

Block 1155: 0x0010FF40 - 0x0010FF7F (64B)

Block 1156: 0x0010FF80 - 0x0010FFBF (64B)

Block 1157: 0x0010FFC0 - 0x0010FFFF (64B)

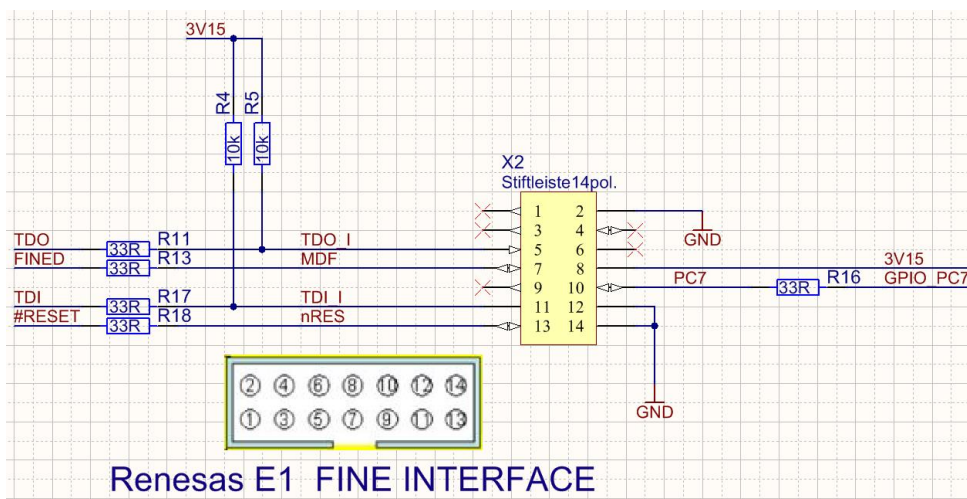

2.2.3 Adjusted output

The 6V2 output of X1 incorporates an output current limitation circuit. This circuit is used to limit the inrush current into any circuitry that is connected to the power rail. Per default, the current limit is adjusted to 16mA. The bus current used by the commModule MBP has to be set accordingly in the commScripter data. The delivered setting for the commModule MBP is 26 mA.

The output current limit of this rail may be altered using following procedure:

1. Connect an amp meter between pins 5 and 6 of X1 (short circuit of the output)
2. Power up the commModule MBP
3. Adjust R29 to the desired current limit value



Note

Currently, the 3V15 output does not feature an output current limit circuit.

For reference, see the current output limitation circuit below:

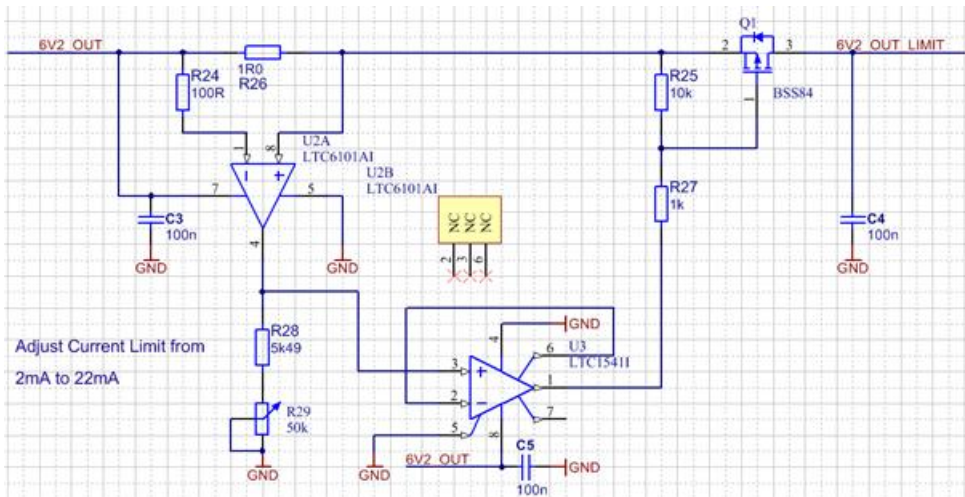

2.3 External interfaces

The commModule-MBP Evaluation-Kit exhibits following external interfaces:



2.3.1 Fieldbus

Polarity independent fieldbus interface.

Connect fieldbus to 3-pol screw connector Pin 1 and Pin 3, Pin 2 is n.c.

Connector:

Phoenix Mini Combicon type: MC 1:5/3-STF-3:81

2.3.2 HART/Modbus

Connector:

Phoenix mini combicon type: MC 1.5/6-STF-3:81

Connector Pin	Signal	Direction	Description
1	RXD	input	HART/Modbus serial interface receive signal
2	TXD	output	HART/Modbus serial interface transmit signal
3	RTS	output	HART/Modbus serial interface request to send signal
4	3V1	power	3.15V power output
5	6V2/CTS	power	6.2V power output or CTS signal dependent on setting on Jumper X11. The default setting is 6V2.
6	GND	power	power and signal GND

2.3.3 LED

An LED light is visible through an LED pipe on the front cover.

When the FF stack is executed the LED indicates the token ring status. It is lit when the device is in token ring mode.

3 Electrical specifications

3.1 Operating conditions

Unless otherwise noted, all specifications apply over the specified operating temperature.

The normal operating temperature range from -40°C to + 85°C.

3.2 Input and output

Digital port input/output specifications (HART):

Signals RXD, TXD, RTS, CTS

With $V_{CC} = 3.2V \pm 4\%$

Parameter	Symbol	Min	Max	Unit
DI: input low voltage	V_{IL}	-0.3	$V_{CC} \times 0.2$	V
DI: input high voltage	V_{IH}	$V_{CC} \times 0.8$	$V_{CC} + 0.3$	V
DO: output low voltage	V_{OL} @ $I_{OL} = -1mA$		0.5	V
DO: output high voltage	V_{OH} @ $I_{OH} = 1mA$	$V_{CC} - 0.5$		V

Output power specification (HART):

Signals 3V_OUT, 6V2_OUT

The power budget to supply a connected system from fieldbus is limited. It depends on the rated current drawn from the fieldbus, which is adjustable in software from 10mA to 26mA ($P_{max} = \text{approx. } 80mW$).

This power budget is available in sum on two power rails.



Parameter	nom	Min	Max	Unit
3V_OUT ($C_{load} < 2\mu F$) $I_o = 1mA$ $I_o = 10mA$ $I_o = 20mA$	3.2	3.1 3.1 3.1	3.3 3.3 3.3	V
6V2_OUT ($C_{load} < 2\mu F$) (internal series resistance 10 Ohms) $I_o = 1mA$ $I_o = 10mA$ $I_o = 16mA$	6.2	5,.92 5.91 5.82 5.76	6.22 6.21 6.12 6.06	V

3.3 Fieldbus

- Powered from fieldbus 9V to 32V.
- Physical layer according to IEC 61158-2 types 1 and 3 voltage mode, 31.25kBit/s.
- Rated current of commModule MBP adjusted to $I_n = 10mA$ up to 26mA.

Softing Industrial Automation GmbH

Richard-Reitzner-Allee 6
85540 Haar / Germany
<http://industrial.softing.com>

 + 49 89 45 656-340
 + 49 89 45 656-488
 info.idn@softing.com

